

AIRCRAFT WARNING SPHERES

RED - WHITE - ORANGE

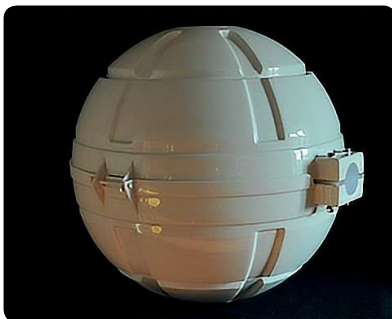

01. DESCRIPTION

Our **warning sphere** is a diurnal marking ball installed on high voltage lines and pylon stays. Very light and resistant to severe weather conditions (extreme cold or high solar exposure), the warning sphere is available in red, white or orange.

The sphere can be adapted on any diameter of Earth cable and thanks to its silicon clamping system, does not require any armor rod to be fixed on the cable.

02. ADVANTAGES

- Exclusive silicon clamping system to ensure stability on the line
- Proven design in operation worldwide, no damage to the cable
- Weather resistant (extreme cold and high solar exposure)
- Physical property retention after UV exposure
- Color stability
- Practical toughness and rigidity
- Dimensional stability
- Adaptable to any diameter of cable or conductor

03. MODELS

| REFERENCE* | COLOR | JAW 07MM (CABLE FROM 10 TO 15MM) | JAW 12MM (CABLE FROM 15 TO 20MM) | JAW 18MM (CABLE FROM 20 TO 26.4MM) |
|------------|--------|--|--|--|
| WS60R-d07 | RED | X | | |
| WS60R-d12 | RED | | X | |
| WS60R-d18 | RED | | | X |
| WS60W-d07 | WHITE | X | | |
| WS60W-d12 | WHITE | | X | |
| WS60W-d18 | WHITE | | | X |
| WS60O-d07 | ORANGE | X | | |
| WS60O-d12 | ORANGE | | X | |
| WS60O-d18 | ORANGE | | | X |

* More références are available for cables of smaller or bigger diameter



04. CHARACTERISTICS

| MECHANICAL | |
|-----------------------|---|
| Body material | Composite |
| Color | Red, White, Orange |
| Mounting | Screws (Included) |
| Diameter | 600mm |
| Thickness | 3mm |
| Weight | < 5 Kg |
| Operating temperature | -55°C to +55°C |
| ENVIRONMENTAL | |
| Humidity | 100% |
| Frost | -60°C |
| Wind speed | 240 Km/h |
| CERTIFICATIONS | |
| CE | EN60947-1 CEI60364, NF C15-100 2014 / 35 / UE |
| OACI | Annex 14, Volume I, Chapter 6 |
| Quality | ISO 9001 ; 2015 |
| WARRANTY | |
| Warranty period | 2 years |

DIMENSIONS

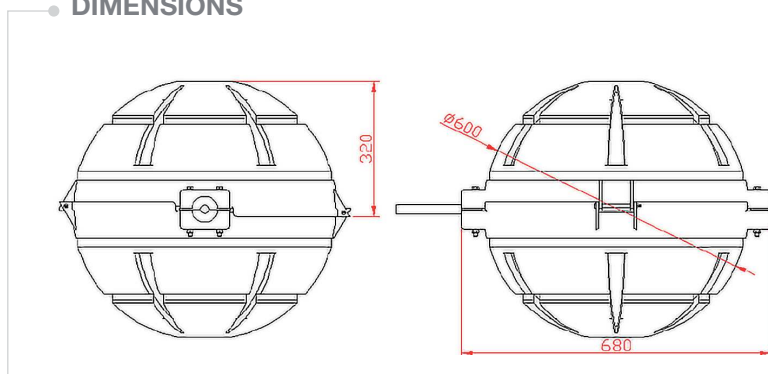

INSTALLATION

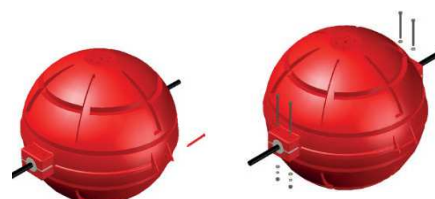
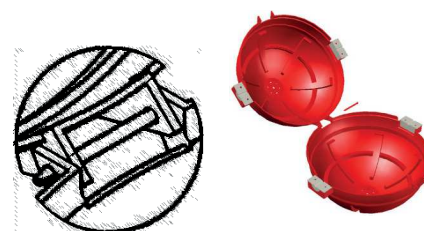

HV Line